

## Push Cars - Built Tough To Last Longer



Nolan's push cars offer a 10,000 lb. (4,536 kg) load capacity. The structural steel frame makes the push cars extra strong to handle the tough working conditions of the railroad industry. Nolan's push cars are designed keeping weight in mind. A retractable center lift ring helps in handling the empty push car. Options include stake pockets, deck dump sills and two- or four-wheel brakes. Push cars are available with either a 3/16" thick steel tread plate deck (**PC-10S**) or a treated tongue-and-groove wood deck (**PC-10W**). Push cars have a 16" wheel tread diameter. Both models PC-10S

and the PC-10W are also available with a 40,000 lb. load capacity.

| DIMENSIONS        | PC-10S                                  | PC-10W                              |
|-------------------|---|-------------------------------------|
| LOAD CAPACITY     | 10,000 lbs. (4,536 kg)                  | 10,000 lbs. (4,536 kg)              |
| DECK CONSTRUCTION | Steel treadplate                        | Tongue-and-groove wood              |
| WEIGHT            | 1,200 lbs. (544 kg)                     | 1,200 lbs. (544 kg)                 |
| LENGTH            | 96" (2,438 mm)                          | 96" (2,438 mm)                      |
| WIDTH             | 67-1/2" (1,714 mm)                      | 67-3/8" (1,711 mm)                  |
| DECK HEIGHT       | 18-1/2" (470 mm)                        | 19-7/8" (505 mm)                    |
| DECK AREA         | 67-1/4" x 84-1/2" (1,708 mm x 2,146 mm) | 67-3/8" x 85" (1,711 mm x 2,159 mm) |
| WHEELBASE         | 50" (1,270 mm)                          | 50" (1,270 mm)                      |
| COUPLING HEIGHT   | 14-1/4" (362 mm)                        | 14-1/4" (362 mm)                    |

Features include:

- Rigid, structural steel frame
- Steel treadplate or treated tongue-and-groove wood deck
- 39-1/2 sq. ft. (3-2/3 m<sup>2</sup>) deck area
- One-piece continuous drawbar with reinforced eye
- One-piece solid axles ride in pillow block roller bearings

## Custom-built Push Cars

Nolan's technical staff can design and custom-build pushcars for your specific applications to handle capacities up to 50,000 lbs. Deck length capacity ranges from six feet to 25 feet, with widths up to 10 feet-5 inches. Options include: fail safe parking or brake systems for one or two axles; 12-volt, electrically operated park or service brakes; options for towing and hitch assemblies; and wheel tread diameters available in 16 and 20 inches, for any track gauge.

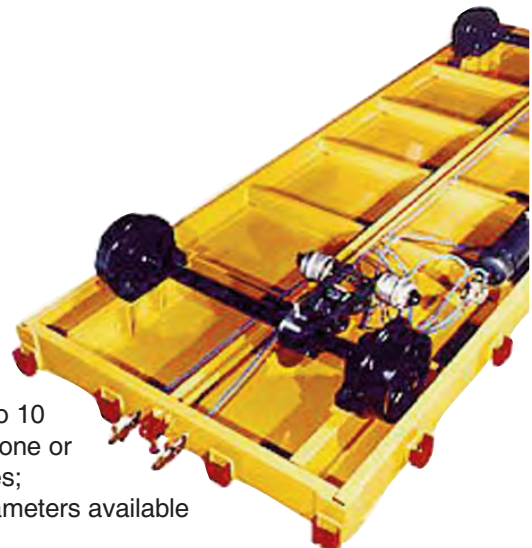
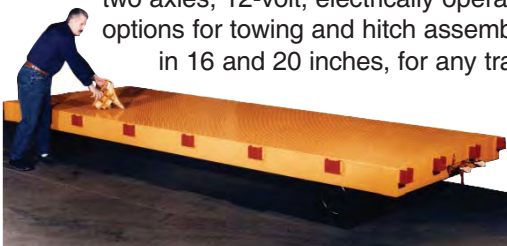

**Call us toll-free 1-800-297-1383  
to place your order today!**

NOTE: Freight is not included in pricing. Shipping is FOB factory. All specifications, prices, and terms are subject to change without notice.

**RAIL PRODUCTS FOR RAILROADS, INDUSTRY, MINES, AND QUARRIES**

## Wheel/Axle and Bearing Assemblies



Nolan's wheel axle and bearing assemblies are adaptable for use with pushcars, trailers, and similar maintenance-of-way applications. Each assembly comes complete with a one-piece tapered axle, two pillow block roller bearings, and two tapered bore 16" ductile iron cast wheels. Assemblies are available in both insulated and non-insulated. Both assemblies are also available with 20" wheels. Wheels are also available separately.

| SPECIFICATIONS    | MODEL #7401-30<br>Heavy Duty / Insulated                  | MODEL #7404-50<br>Extra Heavy Duty / Non-insulated    |
|-------------------|---|---|
| Load Capacity*    | 10,000. lbs. (4,535 kg.)                                  | 20,000. lbs. (9,072 kg.)                              |
| Shipping Weight   | 235. lbs. (107 kg.)                                       | 400. lbs. (181 kg.)                                   |
| Axle Diameter     | 2" (50.8 mm)  | 3" (2,438 mm)   |
| Wheels            | Model #7005   | Model #7001   |
| Fits Track Gauge  | 56-1/2" (1,435 mm)  | 56-1/2" (1,435 mm)                                    |
| Axle Options      | For <i>non-insulated</i> option,<br>order Model #7463-30. | For <i>insulated</i> option,<br>order Model #7462-50. |
| 20" Wheel Options | For <i>20" wheel</i> option,<br>order Model #7422-30.     | For <i>20" wheel</i> option,<br>order Model #7423-50. |

\*Load capacity listed assumes the use of the axle and wheels specified in the table.

**7401-30**  
**\$1,175.78**

**7404-50**  
**\$1,595.80**

NOTE: Freight is not included in pricing. Shipping is FOB factory. All specifications, prices, and terms are subject to change without notice.

**Call us toll-free 1-800-297-1383 to place your order today!**

**RAIL PRODUCTS FOR RAILROADS, INDUSTRY, MINES, AND QUARRIES**